

COMPENSATING CABLE END ASSEMBLY

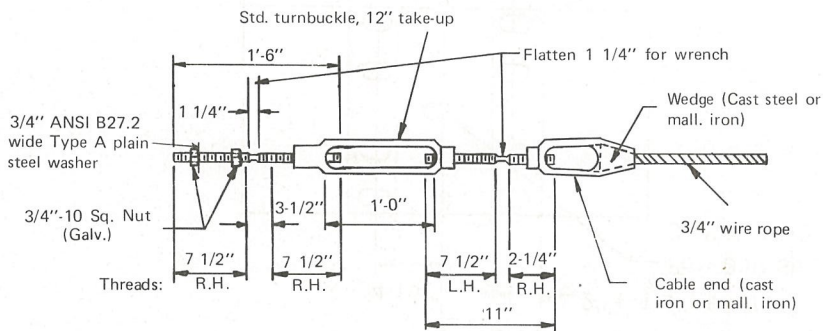

TURNBUCKLE CABLE END ASSEMBLY



3/4" - 3 X 7 WIRE ROPE

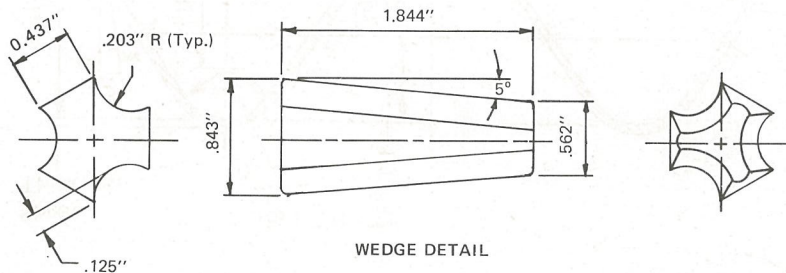

SPECIFICATIONS

Wire rope and connecting hardware shall conform to the requirements of AASHTO M-30 Class A 3/4-inch rope. Connecting hardware shall develop the full strength of a single cable (25,000 lbs). Cast steel components shall conform to the requirements of AASHTO M-103 (ASTM A27). Malleable iron castings shall conform to the requirements of AASHTO M-106 (ASTM A47).

At all locations where the cable is connected to a cable socket with a wedge type connection, one wire of the wire rope shall be crimped over the base of the wedge to hold it firmly in place.

Compensating devices shall have spring constants of 450 pounds per inch, plus or minus 50 pounds per inch, and permit a travel of 6 inches, plus or minus 1 inch.

Sockets baskets shall be designed for use with the wedge detailed in this standard.

Alternate hardware designs will be considered for approval provided their connection details, for the purpose of maintenance substitutions, are compatible with the details of this standard and their operating characteristics are similar to those of the hardware shown in this standard.

Threads of externally threaded parts shall be UNC, Class 2A Tolerance (A.N.S.I. B1.1). Internally threaded parts shall meet the dimensional requirements of ASTM A563.

Dimensional tolerances not shown or implied are intended to be those consistent with the proper functioning of the part, including its appearance and accepted manufacturing practices.

INTENDED USE

This wire rope and associated connecting hardware are used for the rail elements in the standard Cable Guardrail design G1.

3/4" WIRE ROPE (3 X 7)

HM-TF-13

STANDARD

RE-1 -76